

▶ POST PRESS

▶ MAIL ROOM

▶ BOOKBINDERY

We find the right way

RS 255-500 - Stream Separator / Deserter

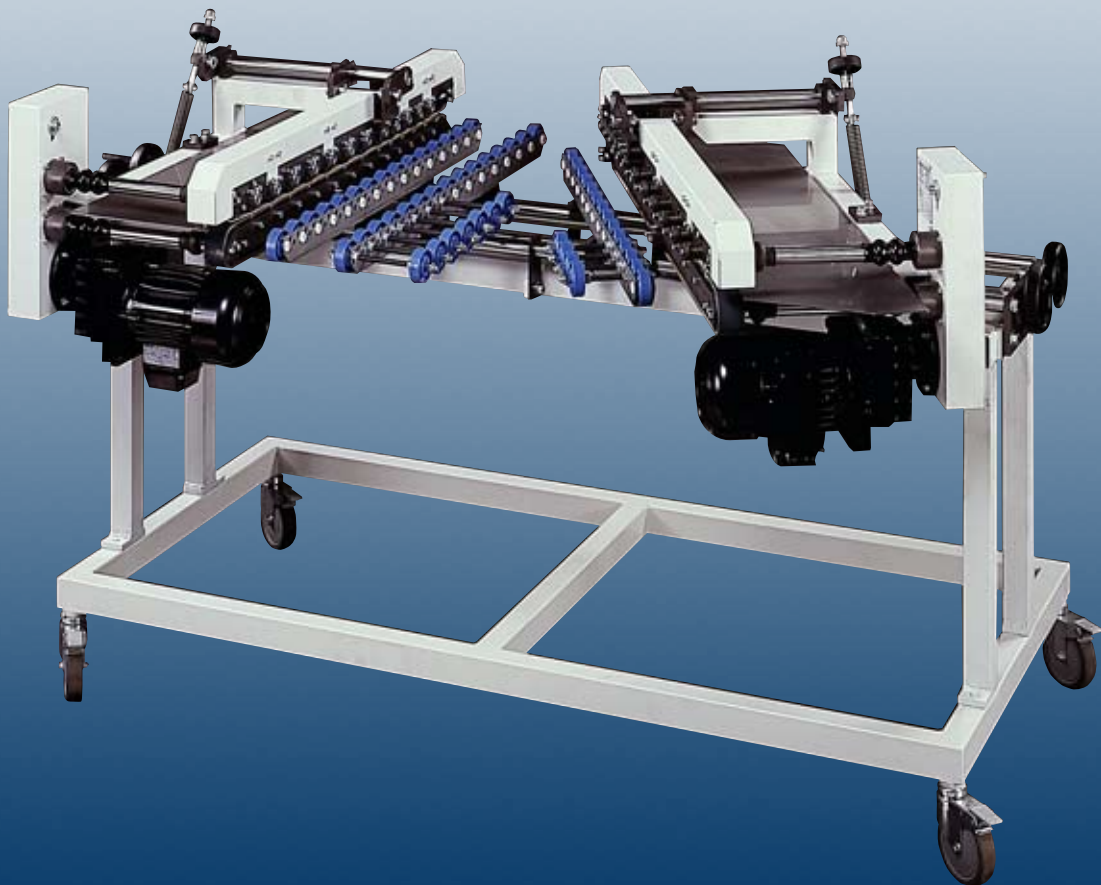

RIMA  **SYSTEM**

Requirements & Solutions

The RS 255-500 Stream Separator / Deserter separates a shingled stream of inserted products into two shingled streams and alternatively separates 2 parallel shingled streams. Format adjustments are easily made during operation. Features like independent conveyor speeds, spring loaded product guides and optimized product supports assure the safe and gentle splitting of the stream even at highest speed. The design of the stream separator, with only one diagonal conveyor, diverts only one shingled stream and standard productions, with non-inserted products, will run straight through the RS 255-500. Another advantage of the RS 255-500 is the customized length of the diagonal belt which can be adjusted to the specific needs of nearly any configuration.

Technical Data

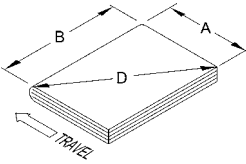
Formats		Minimum	Maximum
	"A" Dimension	100 mm (3.94")	320 mm (12.60")
	"B" Dimension	150 mm (5.91")	485 mm (19.09")
	"D" Dimension	limited by "A" & "B"	limited by "A" & "B"
	Thickness	2 pages @ 80 gr/sqm	16 pages @ 80 gr/sqm
Infeed height		800 mm (31.50")	800 mm (31.50")
Delivery height		800 mm (31.50")	800 mm (31.50")
Lap between inserted copies		35 mm (1.37")	80 mm (3.15")
Speed	> 100.000 products per hour (product permitting)		
Input power	400 V, 3 Ph, N, 0.5 kW		
Weight	approx. 200 kg		
Options	variable length of the diagonal conveyor, bump plate for high speed		

Technical specifications available on request. The manufacturer reserves the right to change the technical specifications without prior notice (RS 255-500-E-04/04).

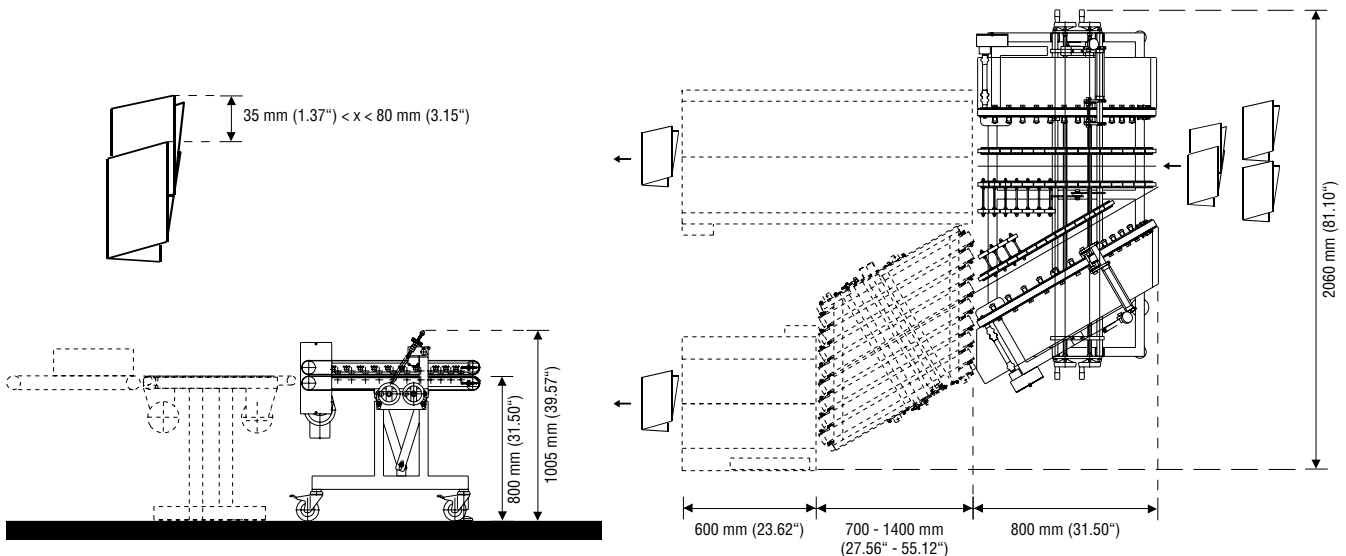

RIMA SYSTEM
www.rima-system.com

RIMA-SYSTEM Corporate Office, USA
5340 Argosy Drive
Huntington Beach, CA 92649
Phone +1 - 714 - 8934534
Fax +1 - 714 - 8927010

RIMA-SYSTEM Atlanta LLC, USA
2840 Johnson Ferry Road, Suite 250
Marietta, GA 30062-8309
Phone +1 - 770 - 998 5622
Fax +1 - 770 - 998 5680

RIMA-SYSTEM Europe, Germany
Postfach 27 03 49, D - 40526 Düsseldorf
Monschauer Str. 1, D - 40549 Düsseldorf
Phone +49 - 211 - 950090
Fax +49 - 211 - 9500911

RIMA-SYSTEM Far East Pte Ltd, Singapore
11 Stamford Road, # 03-10 Capitol Building
Singapore 178884
Phone +65 - 6 338 5580
Fax +65 - 6 338 5582