

▶ POST PRESS

▶ MAIL ROOM

▶ BOOKBINDERY

A sharp solution

RS 831 - Rotary Knife Trimming Line



RIMA  SYSTEM

Requirements & Solutions

The RS 831 is the “all-in-one” rotary trimming line with electric format adjustment. Two trimming units and a bumpturn are mounted on a stable, movable rack. The complete encapsulation of the trimming units ensures a more quiet operation. Proven features like the infeed with “Hexbrator Technology”, “Multi-Knife-Technology”, integrated knife cooling and “Zero Gap Adjustment” guarantee a precise cut, a perfect run-out and a long edge life. Whether head-, foot- or three-side trimming - the RS 831 rotary trimming line fits perfect to all Post Press Systems. Thanks to the electrical format adjustment, the RS 831 is ready for digital workflow and can be operated via a graphical display at the machine or centrally via digital data format (e.g. Job Ticket).

Technical Data

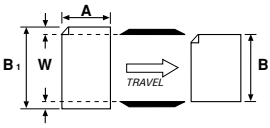
Formats		Minimum	Maximum
	“A” Dimension	114 mm (4.49”)	530 mm (20.87”)
	“B ¹ ” Dimension	98 mm (3.86”) before 1-side trim 101 mm (3.98”) before 2-side trim	530 mm (20.87”) 530 mm (20.87”)
	Diagonal	limited by A & B	limited by A & B
Paper waste	“W” Dimension	3 mm (0.12”)	50 mm (1.97”)
Product width after trimming	“B ² ” Dimension	95 mm (3.74”) after 1-side trim 95 mm (3.74”) after 2-side trim	527 mm (20.75”) 524 mm (20.63”)
Product height	single product shingled stream	2 pages 2 pages	128 pages max 15 mm (0.6”) thickness 512 pages max 15 mm (0.6”) thickness
Speed	adjustable		80 m/min (others on request)
Product orientation	spine leading, spine to the side, spine trailing (product permitting)		
Infeed/delivery height	800 mm (31.50”)		
Input power	400 V, 3 Ph, N, PE, 12 kW (3 knives) / 14 kW (4 knives)		
Air requirement	practically no consumption, 6 bar		
Options	Cold-set option, Multi Knife Technology, Double Trim Technology		

Technical specification available on request. The manufacturer reserves the right to change the technical specifications without prior notice. (RS 831-E-August08).

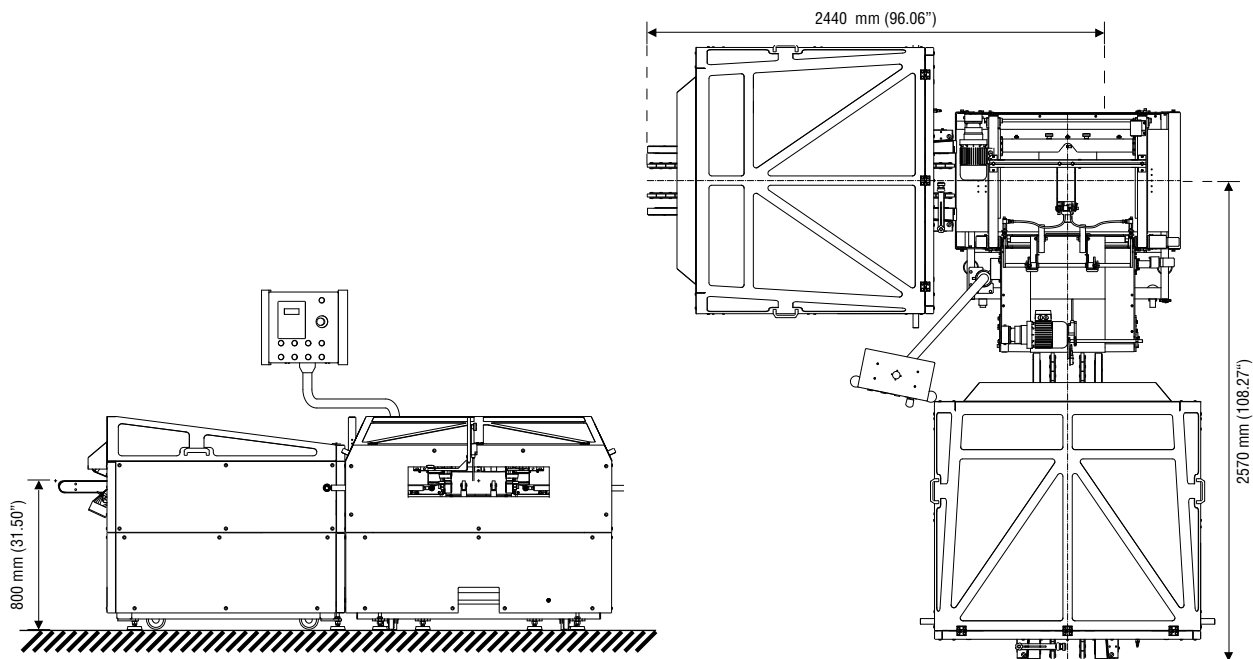

RIMA SYSTEM

www.rima-system.com

RIMA-SYSTEM Europe, Germany · Monschauer Str. 1, D - 40549 Düsseldorf · Telefon: +49 - 211 - 950090 · Telefax: +49 - 211 - 9500911 · info@rima-system.com
 RIMA-SYSTEM Corporate Office, USA · 5340 Argosy Drive · Huntington Beach, CA 92649 · Phone: +1 - 714 - 893 4534 · Fax: +1 - 714 - 892 7010 · rima@rimasystem.com
 RIMA-SYSTEM Atlanta LLC, USA · 2840 Johnson Ferry Road, Suite 250 · Marietta, GA 30062-8309 · Phone: +1 - 770 - 998 5622 · Fax: +1 - 770 - 998 5680 · postpress@rima-system.net
 RIMA-SYSTEM Far East Pte Ltd, Singapore · 11 Stamford Road, 3-10 Capitol Building · Singapore 178884 · Phone: +65 - 6 338 5580 · Fax: +65 - 6 338 5582 · rima@rimasystem.com.sg